

LINK-BELT[®] ULTR-O-LIFE[™] O-RING ROLLER CHAIN



SUPERIOR SEALING AND SELF-LUBRICATION EXTEND CHAIN LIFE FOR SAVINGS IN MAINTENANCE AND GREATER PRODUCTIVITY

No doubt you've seen it before: an application that quickly zaps the life out of conventional roller chains. It's common in applications where relubrication borders on the impossible; or in situations where the chain environment is full of contaminants, requiring frequent and costly labor-intensive maintenance. So for extraordinary applications such as these, Rexnord recommends an extraordinary chain— the Ultr-O-Life[™] O-Ring Roller Chain, specially engineered for demanding applications.

Up to 10 Times More Wear Life than Standard Roller Chain

As the name implies, the Ultr-O-Life[™] O-Ring Roller Chain from Rexnord features specifically designed O-rings in each link. These rings seal in a specially formulated lubricant, virtually eliminating the need for relubrication. Plus the O-rings seal out dirt, moisture, and other contaminants, protecting internal pins and bushings, and offering the ultimate protection against accelerated wear.

The result is a virtually maintenance-free chain that lasts up to three times longer than conventional roller chain in severe duty applications, and up to ten times longer in less demanding applications.

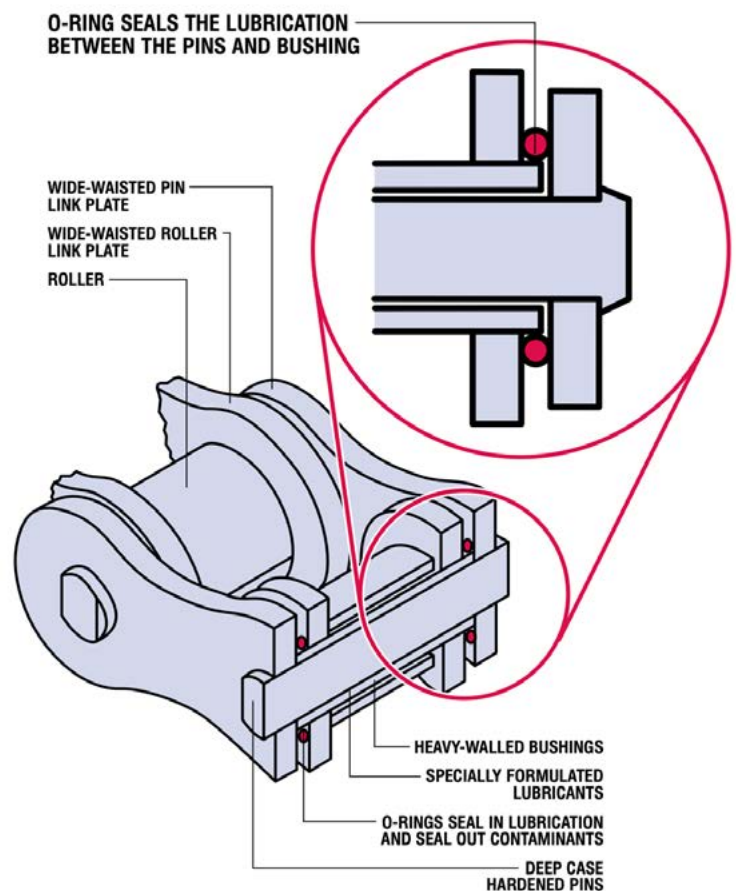

LINK-BELT[®] ULTR-O-LIFE[™] CHAIN LASTS MORE THAN THREE TIMES LONGER THAN STANDARD ROLLER CHAIN

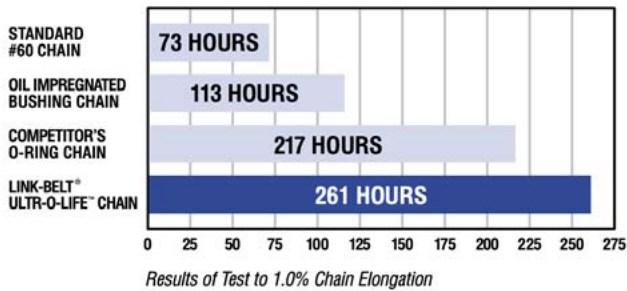

The Right Choice for a Wide Range of Demanding Applications

The Ultr-O-Life's[™] superior sealing and self-lubricating properties are ideally suited for many industrial applications. It's an excellent choice for food and paper applications where ordinary lubricants and lubrication procedures pose an unacceptable contamination risk or equipment wash-down procedures prohibit lubrication effectiveness. In fact, wherever moisture or abrasives are present, the Ultr-O-Life[™] O-Ring Roller Chain is a superior choice.

The Ultr-O-Life[™] O-Ring Roller Chain seals in lubrication and seals out contaminants. So use the Ultr-O-Life[™] O-Ring Roller Chain wherever dirt, mud, moisture or other destructive contaminants penetrate ordinary lubricants to damage pins and bushings. Plus, Ultr-O-Life[™] O-ring seals have been specially designed to trap pre-lube in the joint. That makes the Ultr-O-Life[™] O-Ring Roller Chain the first choice for applications where relubrication is next to impossible.

Link-Belt ULTR-O-LIFE O-Ring Chain

Link-Belt ULTR-O-LIFE[™] O-ring chain is built for applications where relubrication is nearly impossible or where contaminants are excessive resulting in frequent and costly maintenance.

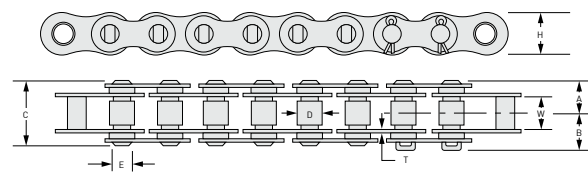

Construction:

Link-Belt O-ring chain uses O-rings to seal in special lubricants protecting the pin/bushing area virtually eliminating the need for relubrication. The O-rings seal out dirt, moisture and other contaminants offering the ultimate protection against accelerated wear.

Advantages:

Link-Belt O-ring chain is easily maintained lasting three to ten times longer than standard series roller chains. Productivity and overall chain economy is dramatically increased while life-cycle costs are decreased. O-ring chains provide greater wear resistance, superior toughness and better operating performance in addition to enhancing equipment maintainability.

Chain Number	Pitch	Dimensions, inches									
		Roller Bushing		Riv. End to Center Line	Conn. End to Overall Center Line	Overall Width	Link Height	Plate Thickness	Pin Diameter	Minimum Ultimate Strength	Aver. Wt. Per Foot
		Width	Diam.								
W	D	A	B	C	H	T	E	Lbs.	Lbs.		
50-OR	0.625	0.38	0.40	0.47	0.55	0.94	0.59	0.08	0.20	4,882	0.71
60-OR	0.750	0.50	0.47	0.56	0.66	1.13	0.70	0.09	0.23	7,030	1.07
80-OR	1.000	0.63	0.63	0.72	0.81	1.44	0.95	0.13	0.31	12,500	1.8
100-OR	1.250	0.75	0.75	0.86	0.98	1.70	1.16	0.16	0.38	19,530	2.0



SCAN THE QR CODE & CONNECT WITH US



Follow us



Join Our Network



Become A Fan