



Cooper understands that achieving performance gains and running existing equipment to its full potential is increasingly important to stay ahead. No one can afford large amounts of machinery downtime, whether it's at scheduled maintenance times or through failures.

We have a proven answer to reducing production loss and overall machinery overheads in key applications, including in a variety of locations on belt and screw conveyors and lifts.

No matter what the industry...

## WHY IS SPLIT THE ANSWER FOR CONVEYORS?

**Is it a struggle to install or service bearings in belt conveyors or bucket elevators, particularly those between head pulley and gearbox or motor?**

The Cooper split roller bearing, highly effective in most locations, is the ideal solution here. Its unique split-to-the-shaft construction allows easy assembly during initial manufacture, and makes it very easy to change out in the field.

Split-to-the-shaft bearings disassemble into smaller components, not only making assembly or changing-out very simple even in the most cramped and inaccessible locations, but also easing lifting and handling. Clearances are pre-set, so no on-site adjustment is needed, and no specialist fitting tools are required.

Productivity is increased and cost reduced, through faster handling and less downtime.

**Ever wished for longer-lasting bearings?**

With their superior sealing, Cooper split roller bearings will outlast conventional bearings over a wide range of conditions, from moderate to extreme. Time and again they have proven their ability to carry on working, even in heavily contaminated conditions and harsh environments, such as below-ground operations or cement plants.



Bearings in a cement plant

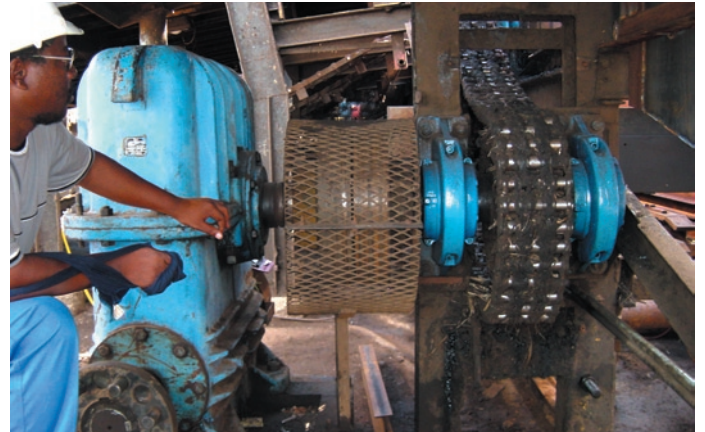

Vertically mounted pillow blocks



Standard hanger unit on a screw conveyor



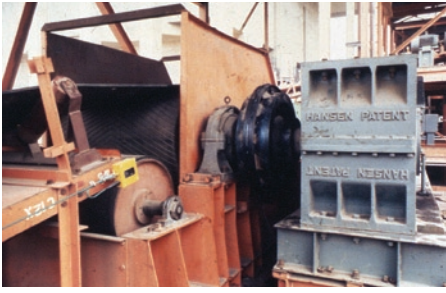

Head drum bearing



Pillow block in a trapped position.



Square flange housing



Cooper flange on a ship loading conveyor



### Tired of bearings that limit your design?

A versatile range of housings, specially designed for conveyors, makes it easy to design our bearings in from the start, or to use them as 'swap-in' replacements for other brands.

As well as pillow blocks and flange housings, we provide specially designed take-up units (available in either push or tension types) that enable easy application of our bearings to the shafts of belt conveyors.

Our hanger units, available in single-, double- and triple-boss versions, allow you to apply Cooper bearings to the centre bearing positions of scroll conveyors. Here, our new 100 Series bearings further increase the benefits of using Cooper; their extra-compact size offering less resistance to the flow of material.

Pillow blocks can be oriented horizontally or at any other angle, giving great design flexibility. If interchangeability is important, or if an existing solid bearing needs replacement, you will find there are no special design requirements: our blocks are available with shaft-height-to-centre and bolt hole patterns to match those of SN, SD and SAF units.

The breadth of our product range makes designing conveyors much easier. Equally important, you can simplify shafts, adjacent components and machinery, without compromising performance, by incorporating split bearings in your design thinking from the outset. You can design each part to do its job without worrying about fitting the bearings in.

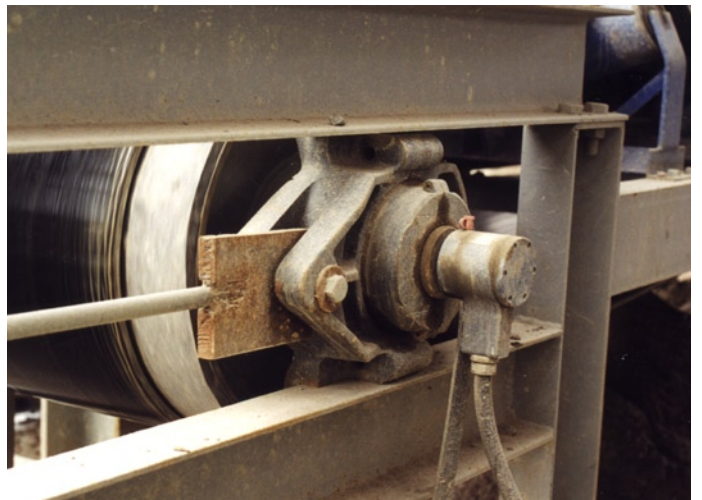

Take - up unit - tension type



Special stainless steel hanger unit

## THE RANGE

Cooper offers a full range of sizes from 35mm to 600mm and four Cooper standard series: 100, 01, 02 and 03 as well as a variety of housings available in cast iron, ductile iron, steel and stainless steel.\*

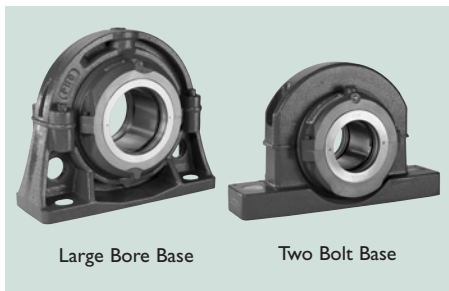

Large Bore Base

Two Bolt Base



Take-Up Units

35mm/1 1/8" to 155mm/6"

Hanger Units

35mm/1 1/8" to 140mm/5 1/2"

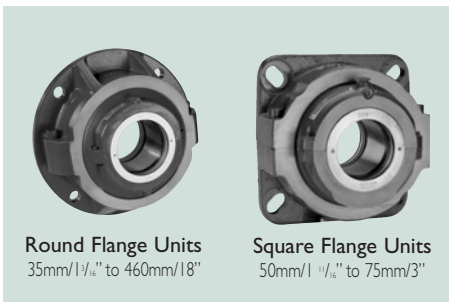

Round Flange Units

35mm/1 1/8" to 460mm/18"

Square Flange Units

50mm/1 1/4" to 75mm/3"

### Seals

Cooper bearings offer superior sealing. Seals are contained in an inner housing (the 'cartridge'), mounted to the pillow block or other outer housing in the manner of a ball and socket joint. The cartridge can take up misalignment between shaft and housing or framework by moving (together with shaft and bearing) up to 2.5°. Being mounted in the cartridge rather than the outer housing, the seals remain concentric with the shaft, maintaining sealing integrity even when there is misalignment.

Whatever your application, we'll find exactly the seal you need within our wide range. 'Everyday' products include a general-purpose felt seal, machined aluminium triple labyrinth, high temperature packing and even lip seals for submerged applications. Where an explosive or corrosive atmosphere prevents the use of aluminium, neoprene rubber triple labyrinth (NTL) seals can be used. For special applications, we supply seals made from non-standard materials as well as bespoke seals or combinations of seals to suit specific operating environments.

#### Felt (F)

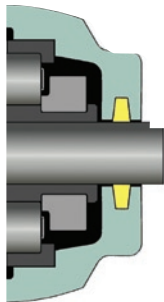

Made from wool and selected fibres. Felt is the current UK and European standard seal for bearings up to 300mm/12" bore size.

#### Aluminium triple labyrinth (ATL)

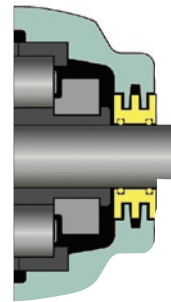

Machined aluminium bodied triple labyrinth seal for high speed and general applications. Supplied as standard in USA and Canada.

#### High Temperature Packing (HTP)

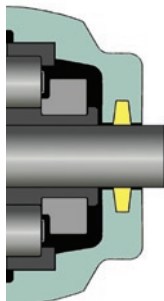

A PTFE filament yarn impregnated with graphite and lubricated with silicon. A direct replacement for felt in high temperature applications. Also available silicon free.

#### Synthetic nitrile rubber single lip (SRS)\*

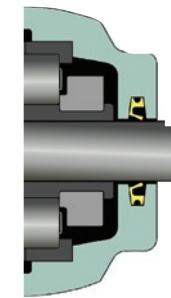

For wet but not submerged applications. Can be used to retain bearing lubricant by mounting lip innermost.

\*For further information, service support incl. installation and training, contact our technical department.

### CUSTOMER SERVICE CENTRES COOPER BEARINGS GROUP

UK, Europe, South America, Asia, Australia and Middle East  
Cooper Roller Bearings Company Ltd.  
Wisbech Road, Kings Lynn, Norfolk, PE30 5JX, United Kingdom

Tel: +44 (0) 1553 763447 Fax: +44 (0) 1553 761113 Email: [CoopersalesUK@kaydon.com](mailto:CoopersalesUK@kaydon.com)

USA and Central America  
The Cooper Split Roller Bearing Corp.  
5365 Robin Hood Road, Suite B, Norfolk, VA 23513, USA.

Tel: +1 (1) 757 460 0925 Fax: +1 (1) 757 464 3067 Email: [CoopersalesUS@kaydon.com](mailto:CoopersalesUS@kaydon.com)

Germany  
Cooper Geteilte Rollenlager GmbH.  
Postfach 100 423, Oberbenrader Str. 407, 47704 Krefeld, GERMANY

Tel: +49 (0) 2151 713 016 Fax: +49 (0) 2151 713 010 Email: [CoopersalesDE@kaydon.com](mailto:CoopersalesDE@kaydon.com)

People's Republic of China  
Cooper Bearings Group Beijing  
Room 909, Canway Building Tower 1, No 66, Nanlishi Road, Xicheng District, Beijing, PRC 100045

Tel: +86 (0) 10 68080803 +86 (0) 10 68080805 +86 (0) 10 68080806  
Fax: +86 (0) 10 68080801 Email: [CoopersalesCN@kaydon.com](mailto:CoopersalesCN@kaydon.com)

Hong Kong  
Cooper Roller Bearings (Hong Kong) Co. Ltd.  
21st Floor Chinachem Tower, 34-37 Connaught Road Central, Hong Kong  
Tel: +852 6050 6633 Tel: +86 (0) 135 7010 7075 Email: [CoopersalesHK@kaydon.com](mailto:CoopersalesHK@kaydon.com)

Brazil  
Cooper do Brasil Ltda.  
Caixa Postal 66.105, CEP 05.314-970, Brasil  
Tel: +55 (0) 11 3022 3706 Tel: +55 (0) 11 9156 2500 Email: [CoopersalesBR@kaydon.com](mailto:CoopersalesBR@kaydon.com)

India  
Cooper Roller Bearings Company Ltd.  
Wisbech Road, Kings Lynn, Norfolk, PE30 5JX, United Kingdom  
Tel: +91 (0) 9820180089 Email: [CoopersalesIN@kaydon.com](mailto:CoopersalesIN@kaydon.com)