

HYDRA-LOCK DESICCANT BREATHERS



LOCK WATER & OTHER CONTAMINANTS OUT OF YOUR GEARBOX WITH DODGE TORQUE-ARM™ PRODUCTS

GEARING

When a standard filter breather is not enough for a humid environment, Dodge can offer the optional Hydra-Lock line of harsh duty desiccant breathers. These are designed to deliver maximum protection from humidity and contaminants. The breathers not only filter moisture, but also filter particles down to 3 microns. The benefit to the end user is maximum protection for maximum uptime.

Ideal For...

- Higher humidity environments
- Wash-down applications
- Gearboxes in storage
- A higher level of contaminant protection

Specifications:

- Integrated nylon standpipe
- Interior check valves create a nearly sealed system
- Clear polycarbonate casing allows for greater chemical compatibility and vibration resistance
- Multi-tiered filtration process

Benefits:

- Eliminates rust-forming condensation
- Prevents sludge deposits & water-contaminated oil
- Provides longer oil and filter life
- Reduces wear and tear on equipment, prolongs life

Foam Pad

Reduces oil mist exhalation. Ensures outgoing air is evenly dispersed through the filters and desiccant.

Resilient Polycarbonate Body

Shock absorbing, clear casing provides reliable service and easy maintenance.

Desiccant Material

Silica gel absorbs water from incoming air. Indicates condition by change of color from blue to pink.

Filter Element

Patented polyester filter removes contamination to 3-micron.

Threaded Mounting

Easily replaces standard filter/breather cap with one of several adapters.

Interior Check Valve System

Provides system pressurisation, protecting system integrity and reduction of particle contamination. Plugs keep unit inactive until use.

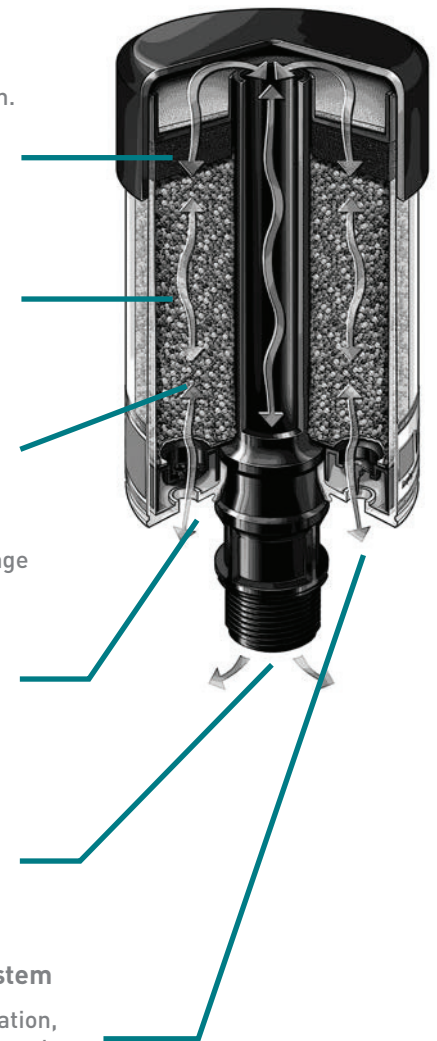

Product Specifications	HLO	HL1	HL2	HL3	HL4
Assembly part number	964372	964364	964366	964368	964370
Unit Height (in/mm)	3.90"/99.06 mm	5.31"/135 mm	6.125"/155.6 mm	8.125"/206.4 mm	10.125"/257.2 mm
Unit Diameter (width in/mm)	2.52"/64.01 mm	2.52"/64 mm	4"/101.6 mm	4"/101.6 mm	4"/101.6 mm
Adsorption Capacity (fl oz/ml)	0.79 fl oz/23.3 ml	1.68 fl oz/49.6 ml	4.00 fl oz/118.2 ml	7.45 fl oz/220.3 ml	11.3 fl oz/333 ml
Filtration	3µ absolute (β3 ≥200)	3µ absolute (β3 ≥200)	3µ absolute (β3 ≥200)	3µ absolute (β3 ≥200)	3µ absolute (β3 ≥200)
Operating Temp. Range (°F)	neg. 20 to 200	neg. 20 to 200	neg. 20 to 200	neg. 20 to 200	neg. 20 to 200
Operating Temp. Range (°C)	neg. 29 to 93	neg. 29 to 93	neg. 29 to 93	neg. 29 to 93	neg. 29 to 93
Thread Connection Size (NPT)	3/8"	3/8"	1"	1"	1"
Recommended for Dodge Reducer Sizes:	TA0107-TA3203: MTA2&3: TXT1-TXT4	TA4207-TA9415: MTA4-8: TXT5 - TXT9	TA10507-TA12608: TXT10- TXT12 : TDT13-TDT15 : MagnaGear 100-390	MagnaGear 525-920	MagnaGear Extreme Duty Applications

BREATHERS FOR ANY APPLICATION

From a standard filter breather to a fully enclosed chamber breather. This allows the customer to pick their desired level of protection.



Totally Enclosed Chamber Breather

- Totally enclosed metal breather
- Allows no outside air to enter the reducer
- Expands and contracts with pressure
- Good for high humidity/wet environments



Hydra-Lock Desiccant Breathers

- Internal check valve system creates a nearly sealed system
- Integrated nylon standpipe and clear Polycarbonate casing allow for greater chemical Compatibility and vibration resistance
- Filter element captures particles at 3 micron absolute



Standard Filter Breather

- An unconstrained filter element
- A screen below the filter and a cap over the filter
- A larger opening below the filter
- A taller overall height helps to avoid dust buildup around opening



40 Micron Filter Breather

- 40 micron ceramic filter
- Metal cap
- Corrosion resistant

Product Specifications	Std Filter Breather	40 Micron Ceramic	Hydra-Lock Desiccant	Enclosed Chamber
Assembly part number	900287 / 904287	430048 / 430049	964372 / 964364 / 964366	240050 / 240051
Filtration	N/A	40µ (β3 >200)	3µ absolute (β3 >200)	totally enclosed
Operating Temp. Range (°F)	N/A	N/A	neg. 20 to 200	N/A
Operating Temp. Range (°C)	N/A	N/A	neg. 29 to 93	N/A
Thread Connection Size (NPT)	3/8"	3/8"	1"	1"
Recommended for Dodge Reducer Sizes:	TA0-TA3: MTA2&3/TA4-TA12 : MTA4-8 TXT1-TXT4/TXT5-TXT12	TA0-TA3: MTA2&3/TA4-TA12 : MTA4-8 TXT1-TXT4/TXT5-TXT12	TA0-TA3 : MTA2&3/TA4-TA9 : MTA4-8/TA10-TA12 TXT1-TXT4/TXT5-TXT9/ TXT10-TDT15	TA0-TA3: MTA2&3/TA4-TA12 : MTA4-8 TXT1-TXT9/TXT10-TDT15

CONTACT AN APPLIED® REPRESENTATIVE TODAY!



22 Stamford Road
Oakleigh, VIC 3166
Phone: (03) 9567 8700

APPLIEDAU.COM

