

**SCHAEFFLER**



## **Split Spherical Roller Bearings**

**FAG**



# Contents

	Page
<b>Features</b>	
Cost savings .....	2
Replacement for bearings with adapter sleeve .....	3
Mounting in split plummer block housings .....	4
Application examples .....	6
Product range .....	9
Bearing design.....	9
<b>Design and safety guidelines</b>	
Load carrying capacity .....	11
Speed suitability.....	11
Fits .....	11
Lubrication .....	12
FAG SmartCheck .....	13
Mounting of split spherical roller bearings.....	13
<b>Dimension tables</b>	
FAG spherical roller bearings, split, metric sizes .....	16
FAG spherical roller bearings, split, inch sizes .....	22

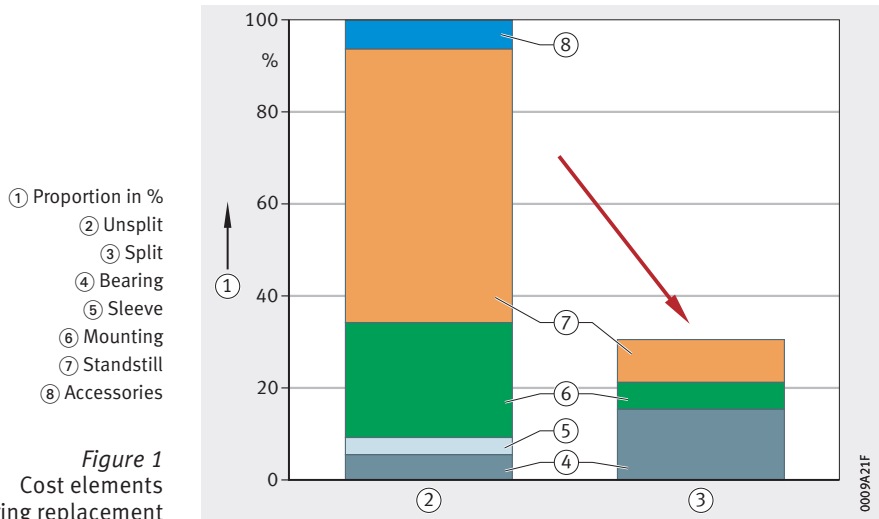
# Split FAG spherical roller bearings

**Features** Spherical roller bearings are double row units comprising solid outer rings with a concave raceway, solid inner rings and barrel rollers with cages. The symmetrical barrel rollers orient themselves freely on the concave outer ring raceway. As a result, shaft flexing and misalignment of the bearing seats are compensated.

In split spherical roller bearings, the inner ring, outer ring and cage with the roller set are split in half. The split bearing rings are held together by screws.

**Cost savings** Split spherical roller bearings are principally used where the replacement of unsplit spherical roller bearings would require costly additional work, involving the removal of gears or couplings, the dismantling of drives or the dismantling of shaft power trains. The use of split spherical roller bearings reduces the downtime of machinery and plant.

In new designs too, split spherical roller bearings can give cost savings in many cases since the plant can be simplified and the assembly work required is reduced. Due in particular to the reduced downtime, the mounting of split spherical roller bearings gives a significant reduction in mounting costs, *Figure 1*.

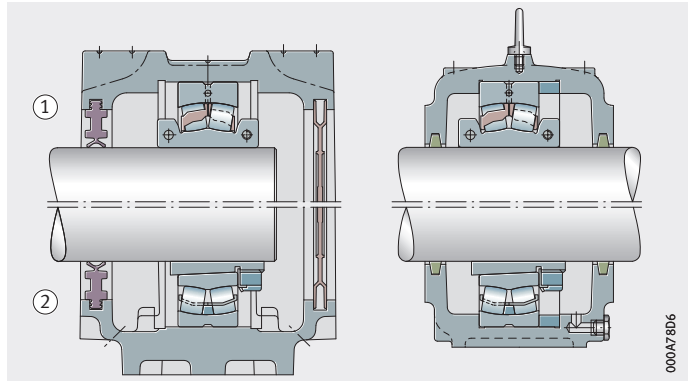


## Replacement for bearings with adapter sleeve

Split spherical roller bearings can generally be mounted instead of unsplit spherical roller bearings with adapter sleeves. The preconditions for replacement are that the outside diameter, outer ring width and diameter of the shaft seat are identical and that the bearings are suitable for the load case, *Figure 2*.

- ① Split spherical roller bearing
- ② Unsplit spherical roller bearing with adapter sleeve

*Figure 2*  
Simple bearing replacement



# Split FAG spherical roller bearings

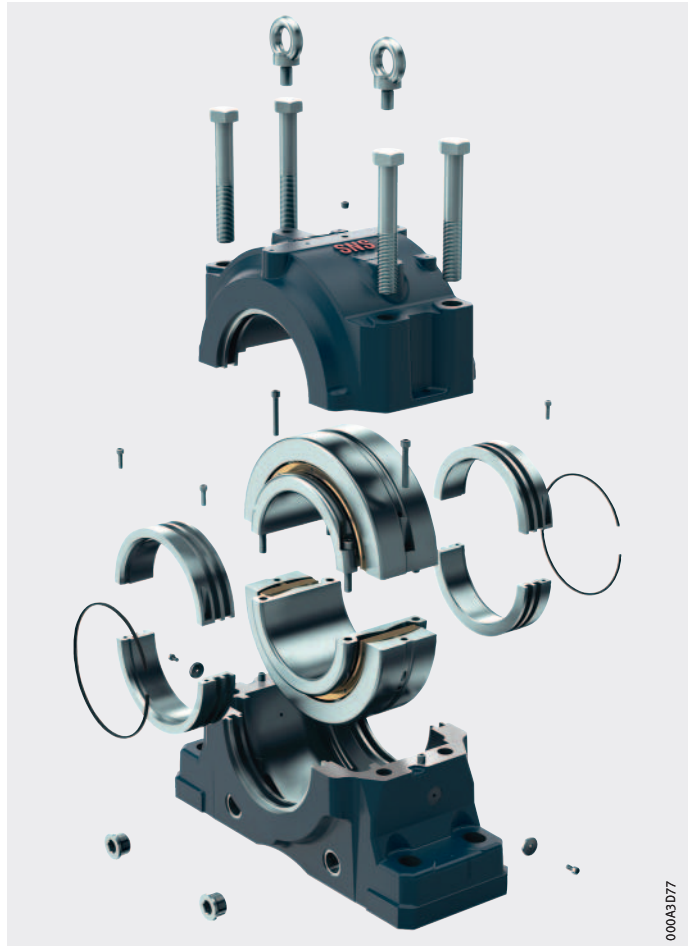
## Mounting in split plummer block housings

Split spherical roller bearings can in many cases be mounted in our split plummer block housings. At difficult to access locations in particular, this combination of a split bearing and split housing gives considerably easier mounting of bearings, *Figure 3*, page 5.

The housings are specifically designed for the location of spherical roller bearings. Split FAG plummer block housings and the associated bearings form bearing arrangement units that can be matched, through the specific selection of seal design, lubrication type and bearing mounting, to a wide range of requirements.

The suitable housing for your split FAG spherical roller bearing can be found in the dimension tables starting from page 16.

In order to ensure selection of the correct combination of housing and bearing when using split bearings, please contact Schaeffler.



*Figure 3*  
Split spherical roller bearing  
in a split SNS housing  
with split labyrinth seal

**Further information**

- TPI 231, Split Plummer Block Housings SNS
- TPI 175, Split Plummer Block Housings SNV.

# Split FAG spherical roller bearings

## Application examples

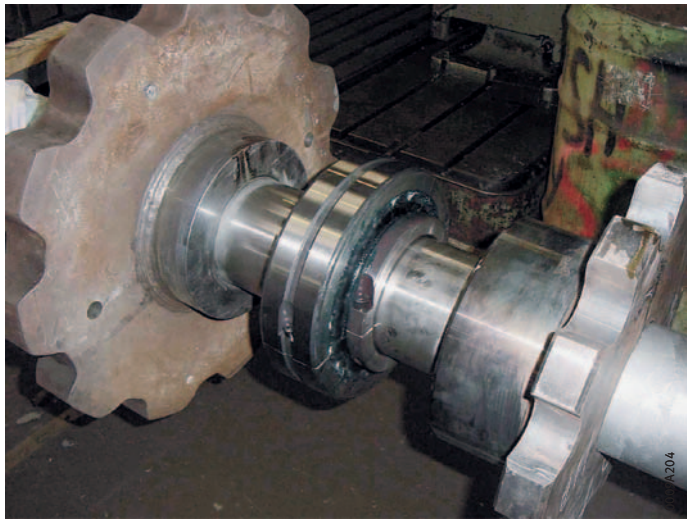
A common application for split spherical roller bearings is on shafts supported at several points and difficult to access mounting locations. Typical areas of application include conveying equipment, materials processing plant, ventilation plant, rolling mills, ships and paper machinery.

Application examples in mining and materials processing, *Figure 4* and *Figure 5*, page 7:

- Bucket wheel excavators and reclaimers
- Winches and sheaves, drive and transmission shafts
- Worm conveyors, bucket conveyors and conveyor belts
- Mixing and stirring plant, mills and crushers
- Sintering plant, rotary kilns
- Fans and ventilators, dust extraction plant.



*Figure 4*  
Bearing arrangements  
in comminution and  
processing plant



*Figure 5*  
Drive bearing arrangements  
in conveying and  
transport equipment

## Split FAG spherical roller bearings

Application examples in the pulp and paper industry, *Figure 6* and *Figure 7*:

- Fans and ventilators
- Mixing and stirring plant
- Dryer rolls
- Drive and transmission shafts
- Conveying equipment
- Comminution machinery.

*Figure 6*  
Bearing arrangements  
in fans and ventilators



*Figure 7*  
Mounting of a large split spherical  
roller bearing



## Product range

The comprehensive range contains split spherical roller bearings for metric shaft diameters from 55 mm to 630 mm and for inch size shafts from  $2\frac{3}{16}$  inch to 16 inch.

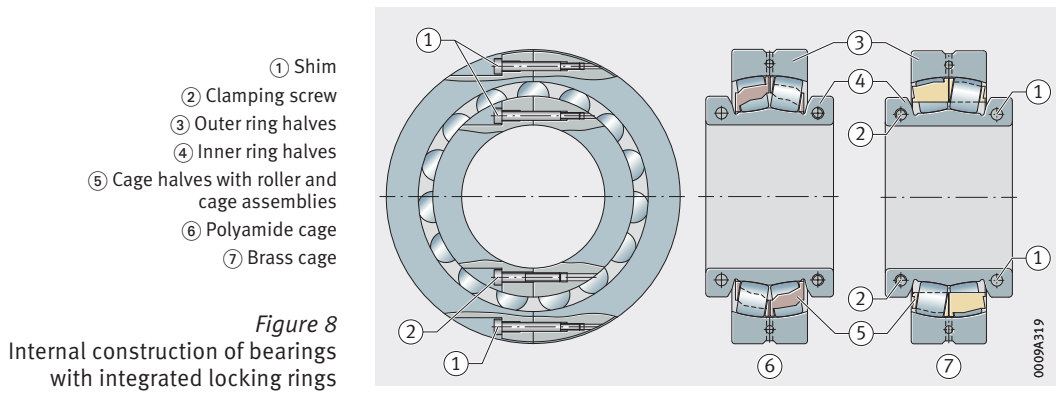
In most cases, the outside diameter, outer ring width and diameter of the shaft seat are identical to those of standard spherical roller bearings of series 222, 230, 231, 239, 240 and 241 with appropriate adapter sleeves.

Which standard bearing with a sleeve can be replaced by the split bearing is shown in the dimension tables.

## Bearing design

Split spherical roller bearings have a cylindrical bore.

The internal construction of most split spherical roller bearings was carried over from our proven spherical roller bearing, *Figure 8*.



## Split FAG spherical roller bearings

The bearings have a split solid cage made from glass fibre reinforced polyamide or brass, see Catalogue HR 1, Rolling Bearings.

Split spherical roller bearings have the normal tolerances of unsplit radial bearings and the normal internal clearance of unsplit spherical roller bearings with a cylindrical bore (ISO 492:2014).

In most split spherical roller bearings, the locking rings are integrated in the inner rings, *Figure 9*.



*Figure 9*  
Split spherical roller bearing with split solid cage made from glass fibre reinforced polyamide or brass, with integral locking rings

If there are large differences in temperature between the shaft and inner ring halves, which can occur for example in dryer rolls for paper machinery, bearings with separate locking rings are more suitable, *Figure 10*.



*Figure 10*  
Split spherical roller bearing for special applications with separate, split locking rings

## **Design and safety guidelines**

### **Load carrying capacity**

Due to the screw connection in the outer ring, the pitch circle for the rolling element set is smaller than that of an unsplit spherical roller bearing. As a result, the load carrying capacity of split spherical roller bearings is lower by comparison. Since they contain the maximum number of rollers with the largest possible dimensions, they can nevertheless achieve a high load carrying capacity.

The overrolling of the joints is taken into consideration in calculation of the equivalent dynamic load by applying the shock factor 1,1. Dimensioning is carried out according to the normal calculation method from Catalogue HR 1, Rolling Bearings.

### **Speed suitability**

The dimension tables give the limiting speeds.

The values take account of the cage strength and the vibrations generated through overrolling of the joints. If the limiting speeds are exceeded, consultation with Application Engineering is required.

### **Fits**

In order that the inner rings have the necessary tight fit once the screws have been tightened, the shaft must be machined to between h6 and h9. These shaft tolerances are the same as those normally used with unsplit bearings located by means of adapter sleeves. The housing bore is normally machined to H7 or H8.

# Split FAG spherical roller bearings

**Lubrication** Split spherical roller bearings are normally lubricated using grease. The lubrication intervals correspond to those of unsplit bearings. Split spherical roller bearings can also be relubricated via a groove and holes in the outer ring.

The use of split spherical roller bearings in conjunction with the automatic relubrication devices FAG CONCEPT8 or FAG CONCEPT2 is particularly effective. Through controlled relubrication, a sufficient quantity of fresh lubricant is continuously supplied to the contact points of the rolling bearing. This results in a significant increase in bearing life. The devices extend the lubrication and maintenance intervals and prevent undersupply or oversupply of lubricant. Plant downtime and maintenance costs are reduced as a result. The sparing and environmentally friendly use of lubricants contributes to higher cost-efficiency, *Figure 11*.



*Figure 11*  
Plummer block housing SNS with  
automatic lubricator FAG CONCEPT8

**Further information** ■ TPI 252, Automatic Relubrication Devices.

## FAG SmartCheck

Condition monitoring and diagnosis of split spherical roller bearings can be carried out using FAG SmartCheck. This is a cost-effective, innovative online measuring system for the continuous monitoring of machine and process parameters on a decentralised basis.

FAG SmartCheck allows recording of vibrations and process parameters such as speed and temperature and thus facilitates monitoring of the bearings. The automatic alarm threshold adjustment allows a reliable alarm system. The alarm system can be implemented in a WLAN on a smartphone by means of the free-of-charge SmartCheck APP.

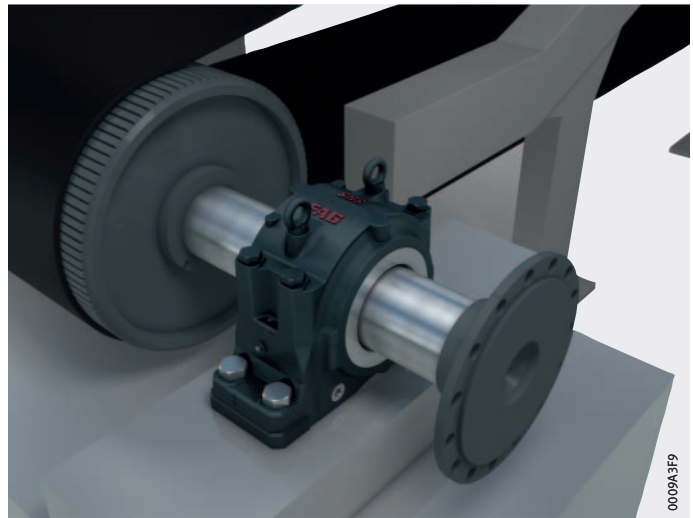
Split FAG plummer block housings SNS are equipped as standard with a connection point to which FAG SmartCheck can be screw mounted. If a suitable connection point with a hole is not present, FAG SmartCheck can be attached by means of adhesive or a magnet.

### Further information

■ TPI 214, FAG SmartCheck.

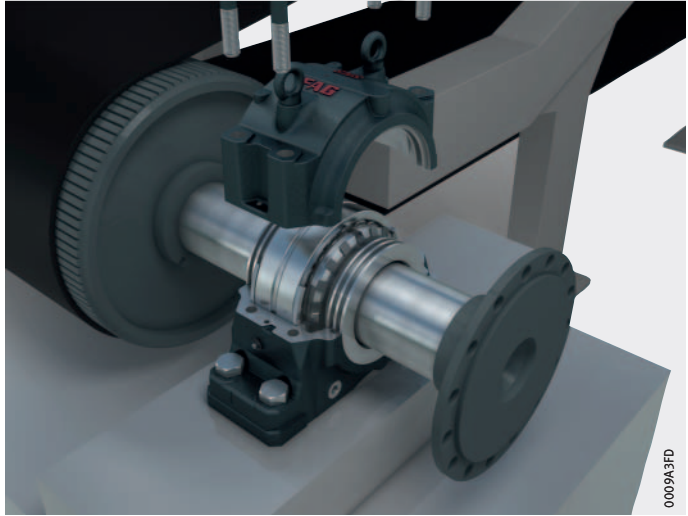
## Mounting of split spherical roller bearings

The following pictures give a summary of the operations in the mounting of split spherical roller bearings. Each bearing is supplied with a comprehensive mounting manual, *Figure 12 to Figure 18*, page 15.

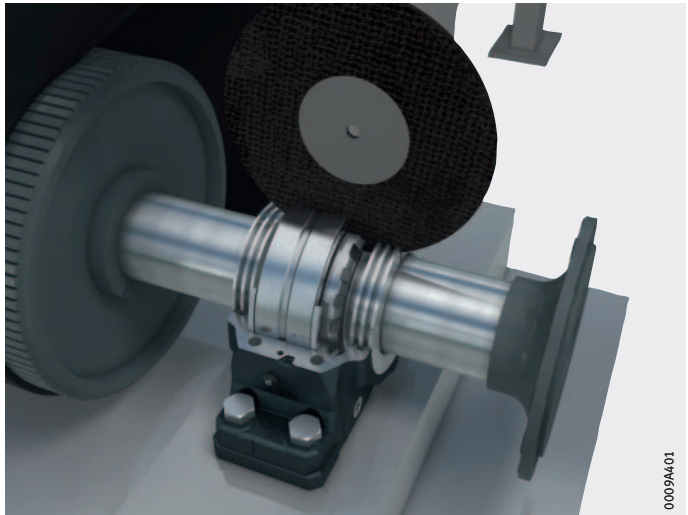


*Figure 12*  
Support the rotor

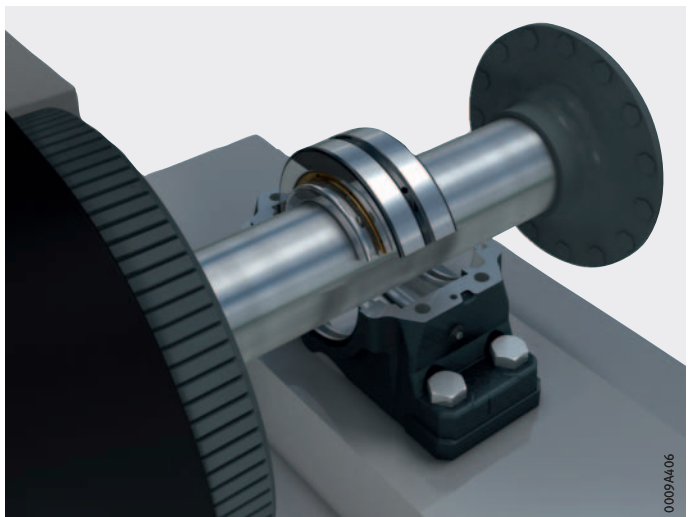
## Split FAG spherical roller bearings



*Figure 13*  
Remove the housing cover

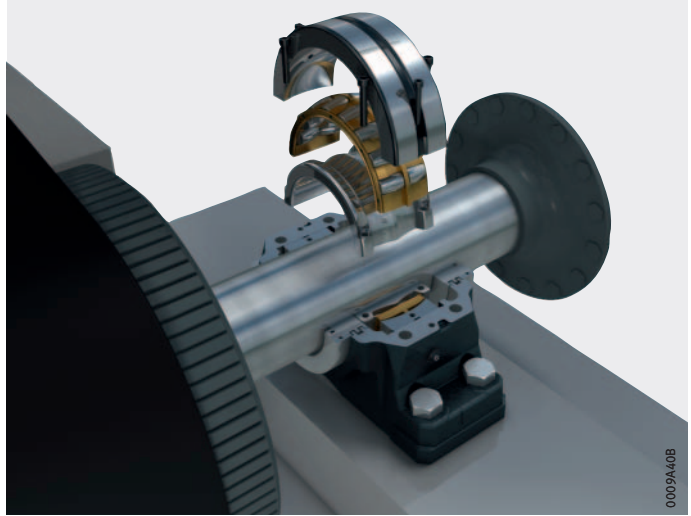


*Figure 14*  
Dismount the old bearing

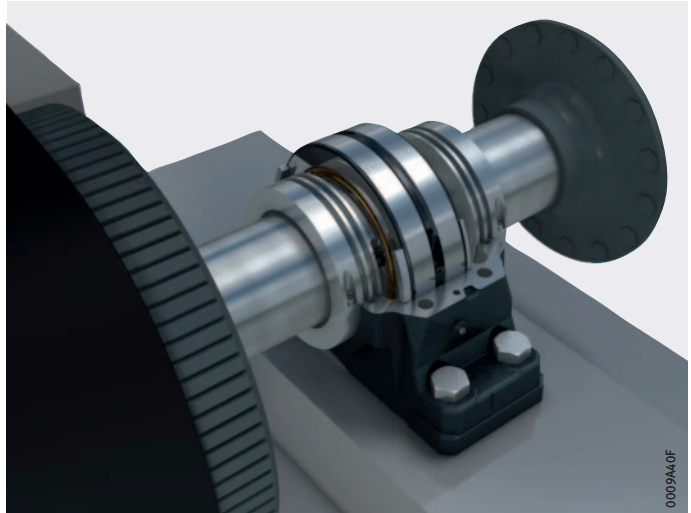


*Figure 15*  
Insert the outer ring half  
in the lower housing section

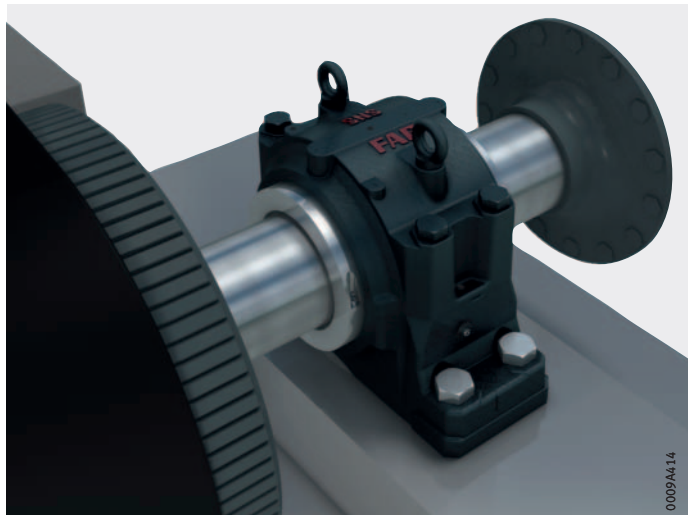
*Figure 16*  
Mount the remaining parts



*Figure 17*  
Lower the shaft

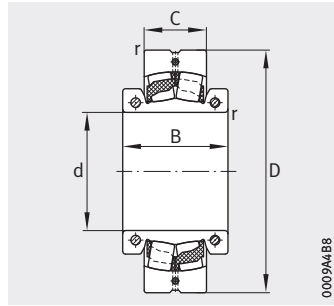


*Figure 18*  
Mount the upper housing section

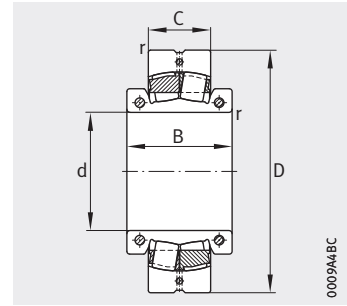


# FAG spherical roller bearings

Split, metric sizes



Solid polyamide cage  
TVPA

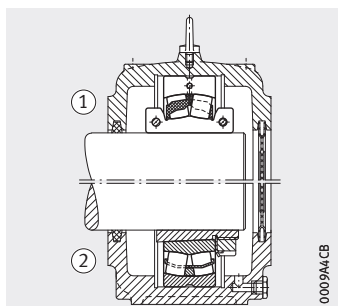


Solid brass cage  
MA

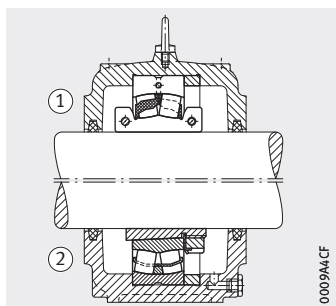
Dimension table · Dimensions in mm

Designation	Mass ≈ kg	Dimensions					Basic load ratings		Calculation factors			
		d	D	C	B	r min.	dyn. C <sub>r</sub> kN	stat. C <sub>0r</sub> kN	e	Y <sub>1</sub>	Y <sub>2</sub>	Y <sub>0</sub>
<b>222SM55-TVPA</b>	1,47	<b>55</b>	110	28	52	1,5	110	130	0,21	3,17	4,72	3,1
<b>222SM60-TVPA</b>	2,08	<b>60</b>	120	31	55	1,5	136	155	0,23	2,98	4,44	2,92
<b>222SM65-TVPA</b>	2,61	<b>65</b>	130	31	60	1,5	172	210	0,24	2,81	4,19	2,75
<b>222SM70-TVPA</b>	3,18	<b>70</b>	140	33	62	2	180	226	0,23	2,95	4,4	2,89
<b>222SM75-TVPA</b>	3,96	<b>75</b>	150	36	68	2	184	237	0,22	3,1	4,62	3,03
<b>222SM80-TVPA</b>	4,82	<b>80</b>	160	40	70	2	213	270	0,22	3,14	4,67	3,07
<b>222SM85-TVPA</b>	5,79	<b>85</b>	170	43	74	2	260	325	0,22	3,04	4,53	2,97
<b>222SM90-TVPA</b>	6,59	<b>90</b>	180	46	76	2,1	285	360	0,23	2,9	4,31	2,83
<b>231SM100-MA</b>	6,8	<b>100</b>	180	56	90	2	310	430	0,28	2,37	3,53	2,32
<b>222SM100-TVPA</b>	10,1	<b>100</b>	200	53	92	2,1	360	460	0,24	2,84	4,23	2,78
<b>230SM110-MA</b>	7,1	<b>110</b>	180	46	86	2	270	385	0,23	2,9	4,31	2,83
<b>231SM110-MA</b>	9,51	<b>110</b>	200	62	102	2	395	570	0,28	2,41	3,59	2,35
<b>222SM110-TVPA</b>	12,1	<b>110</b>	215	58	98	2,1	460	590	0,25	2,71	4,04	2,65
<b>230SM115-MA</b>	10,5	<b>115</b>	200	52	90	2	305	455	0,22	3,04	4,53	2,97
<b>231SM115-MA</b>	11,2	<b>115</b>	210	64	104	2	490	700	0,28	2,39	3,56	2,34
<b>222SM115-TVPA</b>	15,3	<b>115</b>	230	64	104	3	540	720	0,25	2,71	4,04	2,65
<b>230SM125-MA</b>	10	<b>125</b>	210	53	94	2	395	600	0,23	2,95	4,4	2,89
<b>231SM125-MA</b>	13,5	<b>125</b>	225	68	110	2,1	510	750	0,28	2,45	3,64	2,39
<b>222SM125-TVPA</b>	19,3	<b>125</b>	250	68	110	3	630	870	0,26	2,62	3,9	2,56
<b>230SM135-MA</b>	13	<b>135</b>	225	56	100	2,1	405	620	0,22	3,07	4,57	3
<b>231SM135-MA</b>	19,5	<b>135</b>	250	80	123	2,1	570	850	0,27	2,49	3,71	2,43
<b>222SM135-TVPA</b>	24,7	<b>135</b>	270	73	122	3	730	1020	0,25	2,67	3,97	2,61
<b>230SM140-MA</b>	15,5	<b>140</b>	240	60	106	2,1	445	690	0,22	3,1	4,62	3,03
<b>231SM140-MA</b>	25,8	<b>140</b>	270	86	135	2,1	710	1050	0,29	2,32	3,45	2,26
<b>222SM140-TVPA</b>	29,7	<b>140</b>	290	80	124	3	850	1190	0,25	2,69	4	2,63

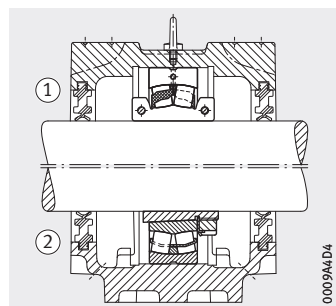
① Split spherical roller bearing. ② Unsplit spherical roller bearing.



Non-locating bearing  
S30



Locating bearing  
S30

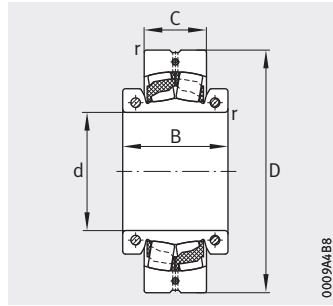


Non-locating bearing  
SNV

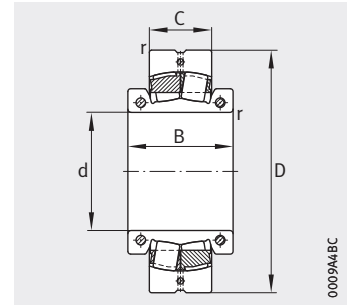
Fatigue limit load $C_{ur}$ N	Permissible axial load $F_a$ max. N	Limiting speed $n_G$ $\text{min}^{-1}$	Screw tightening torque		Replacement of unsplit spherical roller bearings with adapter sleeve		Suitable FAG plummer block housings
			$M_i$ Nm	$M_a$ Nm	Bearing	Adapter sleeve	
13 500	5 400	3 150	8,5	1,5	22212K	H312	SNV110-F-L
15 800	5 400	2 850	8,5	1,5	22213K	H313	SNV120-F-L
19 900	5 400	2 440	8,5	4	22215K	H315	SNV130-F-L
21 800	5 400	2 340	8,5	4	22216K	H316	SNV140-F-L
23 100	7 600	2 280	14	8,5	22217K	H317	SNV150-F-L
26 500	7 600	2 160	14	8,5	22218K	H318	SNV160-F-L
30 000	7 600	1 990	14	8,5	22219K	H319	SNV170-F-L
33 000	7 600	1 820	14	14	22220K	H320	SNV180-F-L
31 000	7 600	1 400	14	4	23122K	H3122	SNV180-F-L
40 500	13 800	1 590	35	14	22222K	H322	SNV200-F-L
30 500	7 600	1 460	14	4	23024K	H3024	S3024-H
40 000	14 000	1 300	35	8,5	23124K	H3124	SNV200-F-L
48 000	13 800	1 430	35	14	22224K	H3124	SNV215-F-L
36 000	7 600	1 390	14	4	23026K	H3026	S3026-H
50 000	7 600	1 200	14	4	23126K	H3126	–
55 000	13 800	1 290	35	14	22226K	H3126	SNV230-F-L
45 000	7 600	1 260	14	4	23028K	H3028	S3028-H
52 000	13 800	1 130	35	8,5	23128K	H3128	–
61 000	13 800	1 170	35	14	22228K	H3128	SNV250-F-L
47 000	13 800	1 200	35	8,5	23030K	H3030	S3030-H
58 000	22 200	1 060	69	14	23130K	H3130	–
76 000	22 200	1 090	69	35	22230K	H3130	SNV270-F-L
52 000	13 800	1 130	35	8,5	23032K	H3032	S3032-H
88 000	22 200	930	69	14	23132K	H3132	–
86 000	22 200	1 020	69	35	22232K	H3132	SNS3038-H-D

# FAG spherical roller bearings

Split, metric sizes



Solid polyamide cage  
TVPA



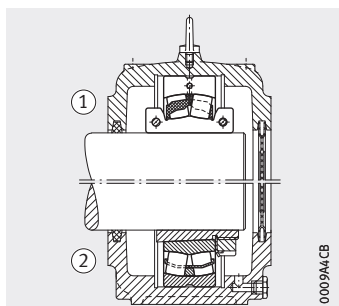
Solid brass cage  
MA

Dimension table (continued) - Dimensions in mm

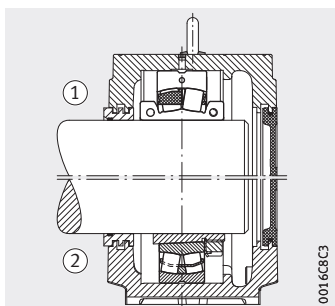
Designation	Mass ≈ kg	Dimensions					Basic load ratings		Calculation factors			
		d	D	C	B	r min.	dyn. C <sub>r</sub> kN	stat. C <sub>0r</sub> kN	e	Y <sub>1</sub>	Y <sub>2</sub>	Y <sub>0</sub>
<b>230SM150-MA</b>	19,2	<b>150</b>	260	67	112	2,1	510	790	0,22	3,1	4,62	3,03
<b>231SM150-MA</b>	28	<b>150</b>	280	88	133	2,1	710	1 050	0,29	2,32	3,45	2,26
<b>222SM150-TVPA</b>	37,4	<b>150</b>	310	86	128	4	960	1 370	0,26	2,64	3,93	2,58
<b>230SM160-MA</b>	25,5	<b>160</b>	280	74	123	2,1	640	1 000	0,23	2,98	4,44	2,92
<b>231SM160-MA</b>	34,9	<b>160</b>	300	96	140	2,1	830	1 230	0,29	2,32	3,45	2,26
<b>222SM160-TVPA</b>	39,4	<b>160</b>	320	86	131	4	960	1 370	0,26	2,64	3,93	2,58
<b>230SM170-MA</b>	23,6	<b>170</b>	290	75	120	2,1	790	1 240	0,23	2,9	4,31	2,83
<b>231SM170-MA</b>	40,6	<b>170</b>	320	104	142	2,1	920	1 430	0,28	2,37	3,53	2,32
<b>222SM170-TVPA</b>	46,4	<b>170</b>	340	92	142	4	1 140	1 640	0,25	2,71	4,04	2,65
<b>230SM180-MA</b>	35	<b>180</b>	310	82	134	2,1	790	1 270	0,23	2,98	4,44	2,92
<b>231SM180-MA</b>	56,4	<b>180</b>	340	112	160	3	1 010	1 540	0,29	2,32	3,45	2,26
<b>222SM180-MA</b>	55,7	<b>180</b>	360	98	154	4	1 140	1 640	0,25	2,71	4,04	2,65
<b>230SM200-MA</b>	41,5	<b>200</b>	340	90	136	3	960	1 540	0,23	2,9	4,31	2,83
<b>231SM200-MA</b>	61,8	<b>200</b>	370	120	175	4	1 320	2 030	0,31	2,21	3,29	2,16
<b>222SM200-MA</b>	73,5	<b>200</b>	400	108	162	4	1 330	1 910	0,25	2,69	4	2,63
<b>230SM220-MA</b>	56,5	<b>220</b>	360	92	156	3	1 110	1 830	0,23	2,9	4,31	2,83
<b>231SM220-MA</b>	86	<b>220</b>	400	128	190	4	1 630	2 600	0,3	2,25	3,34	2,2
<b>222SM220-MA</b>	96,3	<b>220</b>	440	120	170	4	1 470	2 070	0,25	2,71	4,04	2,65
<b>230SM240-MA</b>	57,4	<b>240</b>	400	104	160	4	1 240	2 120	0,22	3,04	4,53	2,97
<b>231SM240-MA</b>	118	<b>240</b>	440	144	210	4	1 880	3 050	0,3	2,28	3,39	2,23
<b>222SM240-MA</b>	129	<b>240</b>	480	130	200	5	1 860	2 600	0,26	2,64	3,93	2,58
<b>230SM260-MA</b>	68	<b>260</b>	420	106	170	4	1 460	2 460	0,23	2,95	4,4	2,89
<b>231SM260-MA</b>	111	<b>260</b>	460	146	190	5	2 300	3 800	0,3	2,23	3,32	2,18
<b>222SM260-MA</b>	147	<b>260</b>	500	130	200	5	2 140	3 300	0,26	2,57	3,83	2,52
<b>230SM280-MA</b>	97	<b>280</b>	460	118	176	4	1 590	2 800	0,22	3,04	4,53	2,97
<b>231SM280-MA</b>	145	<b>280</b>	500	160	218	5	2 330	3 900	0,29	2,32	3,45	2,26
<b>222SM280-MA</b>	184	<b>280</b>	540	140	200	5	2 390	3 550	0,24	2,79	4,15	2,73

① Split spherical roller bearing. ② Unsplit spherical roller bearing.

1) In order to ensure the correct non-locating bearing function, please contact Schaeffler.



Non-locating bearing  
S30

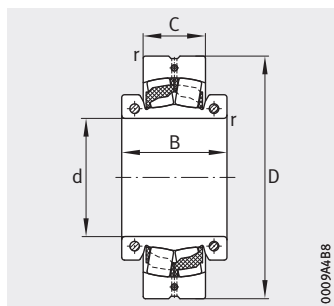


Non-locating bearing<sup>1)</sup>  
SNS

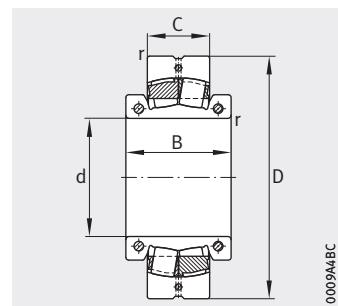
Fatigue limit load $C_{ur}$ N	Permissible axial load $F_a$ max. N	Limiting speed $n_G$ $\text{min}^{-1}$	Screw tightening torque		Replacement of unsplit spherical roller bearings with adapter sleeve		Suitable FAG plummer block housings
			$M_i$	$M_a$	Bearing	Adapter sleeve	
			Nm	Nm			
59 000	13 800	1 060	35	8,5	23034K	H3034	S3034-H
88 000	22 200	930	69	35	23134K	H3134	SNS3134-H-D
97 000	22 200	940	69	35	22234K	H3134	SNS3040-H-D
97 000	22 200	970	69	14	23036K	H3036	SNS3036-H-D
101 000	22 200	870	69	35	23136K	H3136	–
97 000	22 200	940	69	35	22236K	H3136	SNS3138-H-D
115 000	22 200	900	69	8,5	23038K	H3038	–
116 000	22 200	830	69	35	23138K	H3138	SNS3138-H-D
115 000	22 200	860	69	35	22238K	H3138	SNS3140-H-D
117 000	22 200	870	69	14	23040K	H3040	SNS3040-H-D
121 000	22 200	780	69	35	23140K	H3140	SNS3140-H-D
107 000	22 200	790	69	35	22240K	H3140	SNS3048-H-D
138 000	22 200	820	69	35	23044K	H3044X	SNS3044-H-D
154 000	32 000	690	120	69	23144K	H3144X	SNS3144-H-D
125 000	32 000	760	120	69	22244K	H3144X	SNS3148-H-D
155 000	32 000	730	120	35	23048K	H3048	SNS3048-H-D
194 000	32 000	640	120	69	23148K	H3148X	SNS3148-H-D
130 000	32 000	680	120	69	22248K	H3148X	SNS3152-H-D
180 000	32 000	690	120	69	23052K	H3052X	SNS3052-H-D
222 000	32 000	580	120	69	23152K	H3152X	SNS3152-H-D
162 000	60 500	620	295	120	22252K	H3152X	SNS3064-H-D
203 000	32 000	620	120	35	23056K	H3056	SNS3056-H-D
260 000	32 000	510	120	35	23156K	H3156X	SNS3156-H-D
212 000	60 500	600	295	69	22256K	H3156X	SNS3160-H-D
232 000	32 000	590	120	69	23060K	H3060	SNS3060-H-D
270 000	44 000	485	190	120	23160K	H3160	SNS3160-H-D
219 000	60 500	540	295	120	22260K	H3160	SNS3164-H-D

# FAG spherical roller bearings

Split, metric sizes



Solid polyamide cage  
TVPA



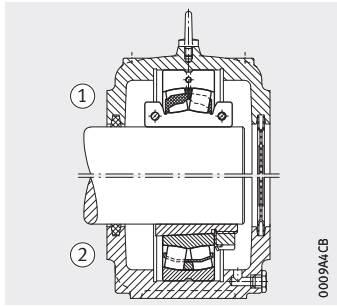
Solid brass cage  
MA

Dimension table (continued) · Dimensions in mm

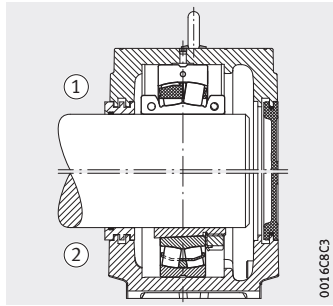
Designation	Mass ≈ kg	Dimensions					Basic load ratings		Calculation factors			
		d	D	C	B	r min.	dyn. C <sub>r</sub> kN	stat. C <sub>0r</sub> kN	e	Y <sub>1</sub>	Y <sub>2</sub>	Y <sub>0</sub>
<b>230SM300-MA</b>	108	<b>300</b>	480	121	186	4	1 870	3 200	0,23	2,9	4,31	2,83
<b>231SM300-MA</b>	184	<b>300</b>	540	176	225	5	2 750	4 700	0,29	2,3	3,42	2,25
<b>222SM300-MA</b>	214	<b>300</b>	580	150	212	5	2 650	4 050	0,24	2,84	4,23	2,78
<b>230SM320-MA</b>	132	<b>320</b>	520	133	200	5	2 060	3 650	0,22	3,04	4,53	2,97
<b>231SM320-MA</b>	226	<b>320</b>	580	190	258	5	3 100	5 200	0,3	2,26	3,37	2,21
<b>222SM320-MA</b>	249	<b>320</b>	620	165	230	6	3 100	4 750	0,24	2,76	4,11	2,7
<b>230SM340-MA</b>	157	<b>340</b>	540	134	205	5	2 380	4 150	0,22	3,01	4,48	2,94
<b>231SM340-MA</b>	314	<b>340</b>	600	192	270	5	3 900	6 800	0,3	2,25	3,34	2,2
<b>222SM340-MA</b>	276	<b>340</b>	650	170	240	6	3 450	5 100	0,25	2,69	4	2,63
<b>230SM360-MA</b>	154	<b>360</b>	560	135	218	5	2 550	4 600	0,22	3,1	4,62	3,03
<b>231SM360-MA</b>	292	<b>360</b>	620	194	270	5	3 900	6 900	0,3	2,28	3,39	2,23
<b>230SM380-MA</b>	204	<b>380</b>	600	148	225	5	2 750	5 100	0,21	3,2	4,77	3,13
<b>231SM380-MA</b>	385	<b>380</b>	650	200	270	6	4 100	7 200	0,28	2,39	3,56	2,34
<b>230SM400-MA</b>	214	<b>400</b>	620	150	225	5	3 100	5 700	0,22	3,1	4,62	3,03
<b>240SM400-MA</b>	313	<b>400</b>	620	200	290	5	3 700	7 900	0,32	2,13	3,17	2,08
<b>231SM400-MA</b>	417	<b>400</b>	700	224	300	6	4 350	7 700	0,28	2,39	3,56	2,34
<b>230SM410-MA</b>	222	<b>410</b>	650	157	225	5	3 150	5 800	0,21	3,2	4,77	3,13
<b>231SM410-MA</b>	566	<b>410</b>	720	226	315	6	5 400	9 700	0,29	2,3	3,42	2,25
<b>230SM420-MA</b>	246	<b>420</b>	650	157	235	5	3 150	5 800	0,21	3,2	4,77	3,13
<b>231SM430-MA</b>	627	<b>430</b>	760	240	344	6	5 500	10 400	0,29	2,33	3,47	2,28
<b>230SM450-MA</b>	291	<b>450</b>	700	165	245	6	3 650	6 900	0,21	3,2	4,77	3,13
<b>230SM470-MA</b>	354	<b>470</b>	720	167	260	6	3 600	7 500	0,23	2,9	4,31	2,83
<b>241SM470-MA</b>	941	<b>470</b>	830	325	420	7,5	7 700	15 500	0,38	1,79	2,67	1,75
<b>230SM500-MA</b>	427	<b>500</b>	780	185	270	6	4 200	8 400	0,2	3,34	4,98	3,27
<b>241SM500-MA</b>	1 100	<b>500</b>	870	335	450	7,5	8 400	17 600	0,39	1,73	2,58	1,69
<b>239SM530-MA</b>	293	<b>530</b>	750	140	225	5	2 750	6 500	0,18	3,85	5,73	3,76
<b>230SM530-MA</b>	555	<b>530</b>	820	195	300	6	4 900	10 500	0,22	3,1	4,62	3,03
<b>241SM530-MA</b>	1 360	<b>530</b>	920	355	500	7,5	9 100	19 200	0,38	1,77	2,64	1,73
<b>239SM560-MA</b>	356	<b>560</b>	800	150	235	5	2 950	7 000	0,17	3,95	5,88	3,86
<b>239SM600-MA</b>	410	<b>600</b>	850	165	250	5	3 850	8 800	0,18	3,66	5,46	3,58
<b>230SM630-MA</b>	955	<b>630</b>	980	230	355	7,5	6 400	13 700	0,22	3,01	4,48	2,94

① Split spherical roller bearing. ② Unsplit spherical roller bearing.

1) In order to ensure the correct non-locating bearing function, please contact Schaeffler.



Non-locating bearing  
S30

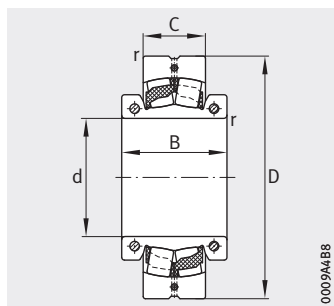


Non-locating bearing<sup>1)</sup>  
SNS

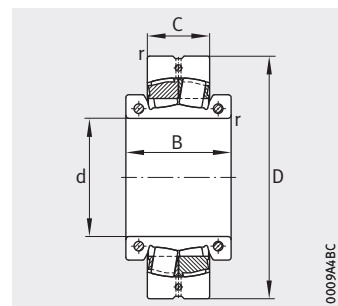
Fatigue limit load $C_{ur}$ N	Permissible axial load $F_a$ max. N	Limiting speed $n_G$ $\text{min}^{-1}$	Screw tightening torque		Replacement of unsplit spherical roller bearings with adapter sleeve		Suitable FAG plummer block housings
			$M_i$ Nm	$M_a$ Nm	Bearing	Adapter sleeve	
260 000	32 000	530	120	69	23064K	H3064-HG	SNS3064-H-D
310 000	60 500	435	295	120	23164K	H3164-HG	SNS3164-H-D
236 000	60 500	480	295	120	22264K	H3164-HG	SNS2264-H-D
290 000	60 500	500	295	69	23068K	H3068-HG	SNS3068-H-D
330 000	60 500	400	295	190	23168K	H3168-HG	SNS2264-H-D
280 000	60 500	450	295	120	22268K	H3168-HG	SNS3268-H-D
320 000	60 500	450	295	35	23072K	H3072-HG	SNS3072-H-D
420 000	60 500	360	295	35	23172K	H3172-HG	–
290 000	60 500	415	295	120	22272K	H3172-HG	SNS3180-H-D
355 000	60 500	435	295	69	23076K	H3076-HG	SNS3076-H-D
425 000	60 500	350	295	69	23176K	H3176-HG	–
360 000	60 500	420	295	120	23080K	H3080-HG	SNS3080-H-D
450 000	60 500	340	295	120	23180K	H3180-HG	SNS3180-H-D
425 000	60 500	385	295	69	23084K	H3084X-HG	SNS3084-H-D
640 000	60 500	310	295	69	24084K	H24084-HG	–
485 000	60 500	325	295	190	23184K	H3184-HG	SNS3184-H-D
430 000	60 500	370	295	120	23088K	H3088-HG	SNS3088-H-D
580 000	60 500	295	295	120	23188K	H3188-HG	–
430 000	60 500	370	295	120	23088K	H3088-HG	SNS3088-H-D
610 000	94 000	280	580	190	23192K	H3192-HG	–
500 000	60 500	335	295	190	23096K	H3096-HG	SNS3096-H-D
440 000	60 500	325	295	120	230/500K	H30/500-HG	SNS30/500-H-D
1 040 000	136 000	224	1 000	295	241/500K	H241/500-HG	–
600 000	60 500	310	295	120	230/530K	H30/530-HG	SNS30/530-H-D
1 310 000	136 000	207	1 000	295	241/530K	H241/530-HG	–
375 000	60 500	325	295	69	239/560K	H39/560-HG	–
690 000	94 200	265	580	120	230/560K	H30/560-HG	–
1 400 000	217 000	197	2 000	295	241/560K	H241/560-HG	–
540 000	60 500	305	295	69	239/600K	H39/600-HG	–
560 000	60 500	280	295	69	239/630K	H39/630-HG	–
970 000	136 000	219	1 000	120	230/670K	H30/670-HG	–

# FAG spherical roller bearings

Split, inch sizes



Solid polyamide cage  
TVPA

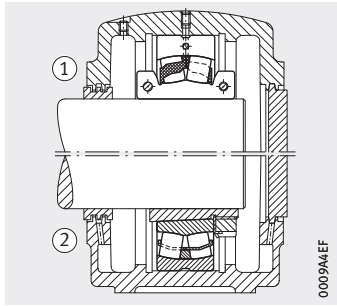


Solid brass cage  
MA

Dimension table · Dimensions in mm

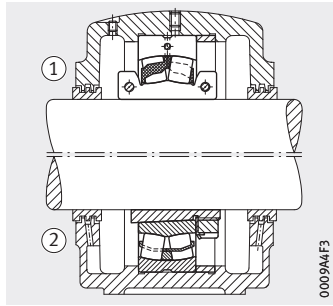
Designation	Mass ≈ kg	Dimensions						Basic load ratings		Calculation factors			
		d		D	C	B	r min.	dyn. C <sub>r</sub> kN	stat. C <sub>0r</sub> kN	e	Y <sub>1</sub>	Y <sub>2</sub>	Y <sub>0</sub>
		inch	mm										
222S.203	2,25	2 <sup>3/16</sup>	55,563	120	31	55	1,5	136	155	0,23	2,98	4,44	2,92
222S.204	2,19	2 <sup>1/4</sup>	57,15	120	31	55	1,5	136	155	0,23	2,98	4,44	2,92
222S.207	2,81	2 <sup>7/16</sup>	61,913	130	31	60	1,5	172	210	0,24	2,81	4,19	2,75
222S.208	2,47	2 <sup>1/2</sup>	63,5	130	31	60	1,5	172	210	0,24	2,81	4,19	2,75
222S.211	3,27	2 <sup>11/16</sup>	68,263	140	33	62	2	180	226	0,23	2,95	4,4	2,89
222S.215	3,94	2 <sup>15/16</sup>	74,613	150	36	68	2	184	237	0,22	3,1	4,62	3,03
222S.300	3,88	3	76,2	150	36	68	2	184	237	0,22	3,1	4,62	3,03
222S.303	4,27	3 <sup>3/16</sup>	80,963	160	40	70	2	213	270	0,22	3,14	4,67	3,07
222S.304	4,22	3 <sup>1/4</sup>	82,55	160	40	70	2	213	270	0,22	3,14	4,67	3,07
222S.307	6,86	3 <sup>7/16</sup>	87,313	180	46	76	2,1	285	360	0,23	2,9	4,31	2,83
222S.307-MA	6,98	3 <sup>7/16</sup>	87,313	180	46	76	2,1	265	320	0,23	2,9	4,31	2,83
222S.308	6,77	3 <sup>1/2</sup>	88,9	180	46	76	2,1	285	360	0,23	2,9	4,31	2,83
222S.308-MA	6,86	3 <sup>1/2</sup>	88,9	180	46	76	2,1	265	320	0,23	2,9	4,31	2,83
222S.315	10,1	3 <sup>15/16</sup>	100,013	200	53	92	2,1	360	460	0,24	2,84	4,23	2,78
222S.400	9,93	4	101,6	200	53	92	2,1	360	460	0,24	2,84	4,23	2,78
222S.403	11,7	4 <sup>3/16</sup>	106,363	215	58	98	2,1	460	590	0,25	2,71	4,04	2,65
222S.407	15,2	4 <sup>7/16</sup>	112,713	230	64	104	3	540	720	0,25	2,71	4,04	2,65
222S.408	15,1	4 <sup>1/2</sup>	114,3	230	64	104	3	540	720	0,25	2,71	4,04	2,65
222S.415	18	4 <sup>15/16</sup>	125,413	250	68	110	3	630	870	0,26	2,62	3,9	2,56
222S.415-MA	17,5	4 <sup>15/16</sup>	125,413	250	68	110	3	580	780	0,26	2,62	3,9	2,56
222S.500	19	5	127	250	68	110	3	630	870	0,26	2,62	3,9	2,56
222S.503	25,3	5 <sup>3/16</sup>	131,763	270	73	122	3	730	1020	0,25	2,67	3,97	2,61
222S.507	30	5 <sup>7/16</sup>	138,113	290	80	124	3	850	1190	0,25	2,69	4	2,63
222S.507-MA	31,1	5 <sup>7/16</sup>	138,113	290	80	124	3	780	1060	0,25	2,69	4	2,63
222S.508	29,8	5 <sup>1/2</sup>	139,7	290	80	124	3	850	1190	0,25	2,69	4	2,63
230S.508-MA	13,7	5 <sup>1/2</sup>	139,7	240	60	106	2,1	445	690	0,22	3,1	4,62	3,03

① Split spherical roller bearing. ② Unsplit spherical roller bearing.



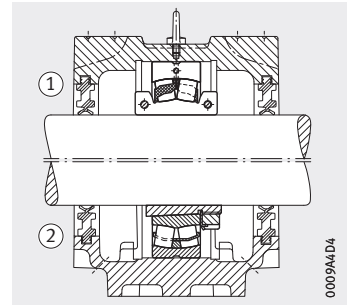
Non-locating bearing  
SAF

0009A4EF



Locating bearing  
SAF

0009A4F3



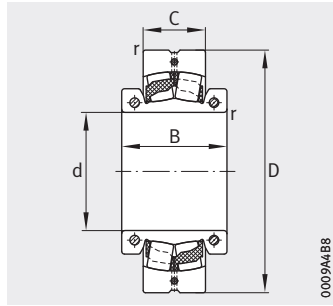
Non-locating bearing  
SNV

0009A4D4

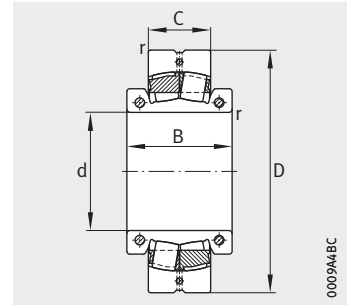
Fatigue limit load $C_{ur}$ N	Permissible axial load $F_a$ max. N	Limiting speed $n_G$ $\text{min}^{-1}$	Screw tightening torque		Replacement of unsplit spherical roller bearings with adapter sleeve			Suitable FAG plummer block housings	
			$M_i$ Nm	$M_a$ Nm	Bearing	Adapter sleeve			
15 800	5 300	2 850	8,5	1,5	22213K	SNW13203	H313X203	SAF513	SNV120-F-L
15 800	5 300	2 850	8,5	1,5	22213K	SNW13204	H313X204	SAF513/21/4	SNV120-F-L
19 900	5 300	2 440	8,5	4	22215K	SNW15207	H315X207	SAF515	SNV130-F-L
19 900	5 300	2 440	8,5	4	22215K	SNW15208	H315X208	SAF515/21/2	SNV130-F-L
21 800	5 300	2 340	8,5	4	22216K	SNW16211	H316X211	SAF516	SNV140-F-L
23 100	7 600	2 280	14	8,5	22217K	SNW17215	H317X215	SAF517	SNV150-F-L
23 100	7 600	2 280	14	8,5	22217K	SNW17300	H317X300	SAF517/3	SNV150-F-L
26 500	7 600	2 160	14	8,5	22218K	SNW18303	H318X303	SAF518	SNV160-F-L
26 500	7 600	2 160	14	8,5	22218K	SNW18304	H318X304	SAF518/31/4	SNV160-F-L
33 000	7 600	1 820	14	14	22220K	SNW20307	H320X307	SAF520	SNV180-F-L
29 500	7 600	1 820	14	14	22220K	SNW20307	H320X307	SAF520	SNV180-F-L
33 000	7 600	1 820	14	14	22220K	SNW20308	H320X308	SAF520/31/2	SNV180-F-L
29 500	7 600	1 820	14	14	22220K	SNW20308	H320X308	SAF520/31/2	SNV180-F-L
40 500	13 800	1 590	35	14	22222K	SNW22315	H322X315	SAF522	SNV200-F-L
40 500	13 800	1 590	35	14	22222K	SNW22400	H322X400	SAF522/4	SNV200-F-L
48 000	13 800	1 430	35	14	22224K	SNW24403	H3124X403	SAF524	SNV215-F-L
55 000	13 800	1 290	35	14	22226K	SNW26407	H3126X407	SAF526	SNV230-F-L
55 000	13 800	1 290	35	14	22226K	SNW26408	H3126X408	SAF526/41/2	SNV230-F-L
61 000	13 800	1 170	35	14	22228K	SNW28415	H3128X415	SAF528	SNV250-F-L
55 000	13 800	1 170	35	14	22228K	SNW28415	H3128X415	SAF528	SNV250-F-L
61 000	13 800	1 170	35	14	22228K	SNW28500	H3128X500	SAF528/5	SNV250-F-L
76 000	22 200	1 090	69	35	22230K	SNW30503	H3130X503	SAF530	SNV270-F-L
86 000	22 200	1 020	69	35	22232K	SNW32507	H3132X507	SAF532	SNV290-F-L
77 000	22 200	1 020	69	35	22232K	SNW32507	H3132X507	SAF532	SNV290-F-L
86 000	22 200	1 020	69	35	22232K	SNW32508	H3132X508	SAF532/51/2	SNS3038-H-D
52 000	13 800	1 130	35	8,5	23032K	-	H3032X508	-	-

# FAG spherical roller bearings

Split, inch sizes



Solid polyamide cage  
TVPA

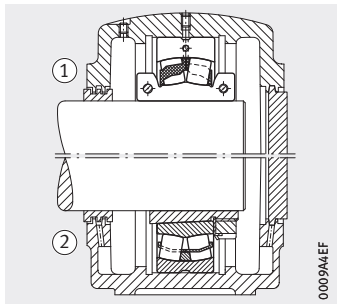


Solid brass cage  
MA

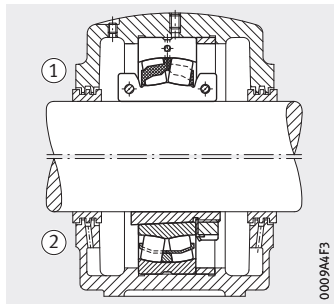
Dimension table (continued) · Dimensions in mm

Designation	Mass ≈ kg	Dimensions						Basic load ratings		Calculation factors			
		d		D	C	B	r min.	dyn. C <sub>r</sub> kN	stat. C <sub>0r</sub> kN	e	Y <sub>1</sub>	Y <sub>2</sub>	Y <sub>0</sub>
		inch	mm										
222S.515	36	5 <sup>15</sup> / <sub>16</sub>	150,813	310	86	128	4	960	1 370	0,26	2,64	3,93	2,58
222S.600	36,9	6	152,4	310	86	128	4	960	1 370	0,26	2,64	3,93	2,58
222S.607	38,5	6 <sup>7</sup> / <sub>16</sub>	163,513	320	86	131	4	960	1 370	0,26	2,64	3,93	2,58
230S.607-MA	24,4	6 <sup>7</sup> / <sub>16</sub>	163,513	280	74	123	2,1	640	1 000	0,23	2,98	4,44	2,92
231S.607	34,8	6 <sup>7</sup> / <sub>16</sub>	163,513	300	96	140	2,1	830	1 230	0,29	2,32	3,45	2,26
222S.608	38,1	6 <sup>1</sup> / <sub>2</sub>	165,1	320	86	131	4	960	1 370	0,26	2,64	3,93	2,58
222S.615	44,2	6 <sup>15</sup> / <sub>16</sub>	176,213	340	92	142	4	1 140	1 640	0,25	2,71	4,04	2,65
231S.615	41,7	6 <sup>15</sup> / <sub>16</sub>	176,213	320	104	142	2,1	920	1 430	0,28	2,37	3,53	2,32
230S.700	21,1	7	177,8	290	75	120	2,1	790	1 240	0,23	2,9	4,31	2,83
231S.700	61,8	7	177,8	340	112	150	3	1 010	1 540	0,29	2,32	3,45	2,26
222S.703	59	7 <sup>3</sup> / <sub>16</sub>	182,563	360	98	154	4	1 140	1 640	0,25	2,71	4,04	2,65
231S.703	50,8	7 <sup>3</sup> / <sub>16</sub>	182,563	340	112	160	3	1 010	1 540	0,29	2,32	3,45	2,26
222S.708	76,8	7 <sup>1</sup> / <sub>2</sub>	190,5	400	108	162	4	1 330	1 910	0,25	2,69	4	2,63
222S.715	75,4	7 <sup>15</sup> / <sub>16</sub>	201,613	400	108	162	4	1 330	1 910	0,25	2,69	4	2,63
231S.715	72,6	7 <sup>15</sup> / <sub>16</sub>	201,613	370	120	175	4	1 320	2 030	0,31	2,21	3,29	2,16
222S.800	74,7	8	203,2	400	108	162	4	1 330	1 910	0,25	2,69	4	2,63
230S.807	58,9	8 <sup>7</sup> / <sub>16</sub>	214,313	360	92	156	3	1 110	1 830	0,23	2,9	4,31	2,83
230S.808	58,9	8 <sup>1</sup> / <sub>2</sub>	215,9	360	92	156	3	1 110	1 830	0,23	2,9	4,31	2,83
230S.900	52,8	9	228,6	360	92	160	3	1 110	1 830	0,23	2,9	4,31	2,83
231S.907	127	9 <sup>7</sup> / <sub>16</sub>	239,713	440	144	210	4	1 880	3 050	0,3	2,28	3,39	2,23
230S.908	56,8	9 <sup>1</sup> / <sub>2</sub>	241,3	400	104	160	4	1 240	2 120	0,22	3,04	4,53	2,97
231S.908	112	9 <sup>1</sup> / <sub>2</sub>	241,3	440	144	210	4	1 880	3 050	0,3	2,28	3,39	2,23
231S.915	116	9 <sup>15</sup> / <sub>16</sub>	252,413	460	146	190	5	2 300	3 800	0,3	2,23	3,32	2,18
230S.1000	71,2	10	254	420	106	170	4	1 460	2 460	0,23	2,95	4,4	2,89
231S.1000	123	10	254	460	146	190	5	2 300	3 800	0,3	2,23	3,32	2,18
231S.1007	116	10 <sup>7</sup> / <sub>16</sub>	265,113	460	146	190	5	2 300	3 800	0,3	2,23	3,32	2,18
230S.1008	64,3	10 <sup>1</sup> / <sub>2</sub>	266,7	420	106	170	4	1 460	2 460	0,23	2,95	4,4	2,89
231S.1015	145	10 <sup>15</sup> / <sub>16</sub>	277,812	500	160	218	5	2 330	3 900	0,29	2,32	3,45	2,26
230S.1100	91,7	11	279,4	460	118	176	4	1 590	2 800	0,22	3,04	4,53	2,97
231S.1100	150	11	279,4	500	160	218	5	2 330	3 900	0,29	2,32	3,45	2,26

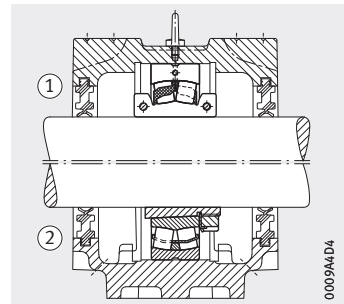
① Split spherical roller bearing. ② Unsplit spherical roller bearing.



Non-locating bearing  
SAF



Locating bearing  
SAF

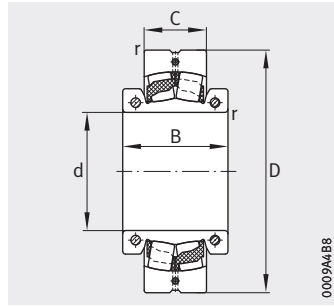


Non-locating bearing  
SNV

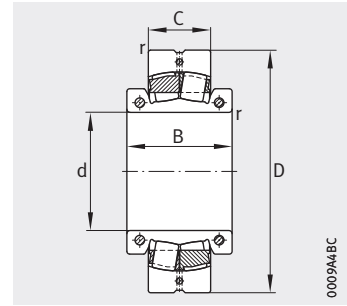
Fatigue limit load $C_{ur}$ N	Permissible axial load $F_a$ max. N	Limiting speed $n_G$ $\text{min}^{-1}$	Screw tightening torque		Replacement of unsplit spherical roller bearings with adapter sleeve			Suitable FAG plummer block housings
			$M_i$ Nm	$M_a$ Nm	Bearing	Adapter sleeve		
97 000	22 200	940	69	35	22234K	H3134X515	SNW34515	SAF534
97 000	22 200	940	69	35	22234K	H3134X600	SNW34600	SAF534/6
97 000	22 200	940	69	35	22236K	H3136X607	SNW36607	SAF536
97 000	22 200	970	69	14	23038K	H3036X607	SNP3036607	SAF038K/67/16
101 000	22 200	870	69	35	23136K	H3136X607	–	–
97 000	22 200	940	69	35	22236K	H3136X608	SNW36608	SAF536/61/2
115 000	22 200	860	69	35	22238K	H3138X615	SNW38615	SAF538
116 000	22 200	830	69	35	23138K	H3138X615	–	–
115 000	22 200	900	69	8,5	23038K	H3038X700	SNP3038700	SAF038K/7
121 000	22 200	780	69	35	23140K	H3138X700	–	–
107 000	22 200	790	69	35	22240K	H3140X703	SNW40703	SAF540
121 000	22 200	780	69	35	23140K	H3140X703	–	–
125 000	32 000	760	120	69	22244K	H3144XX708	SNW44708	SAF544/71/2
125 000	32 000	760	120	69	22244K	H3144XX715	SNW44715	SAF544
154 000	32 000	690	120	69	23144K	H3144XX715	–	–
125 000	32 000	760	120	69	22244K	H3144XX800	SNW44800	SAF544/8
155 000	32 000	730	120	35	23048K	H3048X807	SNP3048807	SAF048K/87/16
155 000	32 000	730	120	35	23048K	H3048X808	SNP3048808	SAF048K/81/2
155 000	32 000	730	120	35	23048K	H3052XX900	SNP3048900	SAF048K/9
222 000	32 000	580	120	69	23152K	H3152XX907	–	–
180 000	32 000	690	120	69	23052K	H3052XX908	SNP3052908	SAF052K/91/2
222 000	32 000	580	120	69	23152K	H3152XX908	–	–
260 000	32 000	510	120	35	23156K	H3156XX915	–	–
203 000	32 000	620	120	35	23056K	H3056X1000	SNP30561000	SAF056K/10
260 000	32 000	510	120	35	23156K	H3156XX1000	–	–
260 000	32 000	510	120	35	23156K	H3156XX1007	–	–
203 000	32 000	620	120	35	23056K	H3056X1008	SNP30561008	SAF056K/101/2
270 000	44 000	485	190	120	23160K	H3160X1015	–	–
232 000	32 000	590	120	69	23060K	H3060X1100	SNP30601100	SDAF060K/11
270 000	44 000	485	190	120	23160K	H3160X1100	–	–

# FAG spherical roller bearings

Split, inch sizes



Solid polyamide cage  
TVPA

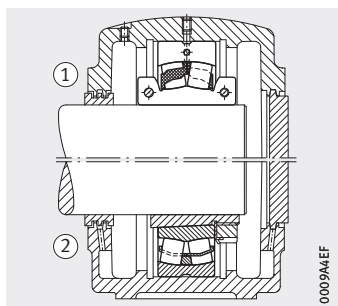


Solid brass cage  
MA

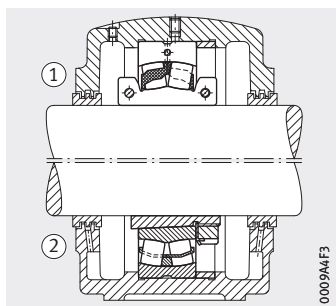
**Dimension table** (continued) · Dimensions in mm

Designation	Mass ≈ kg	Dimensions						Basic load ratings		Calculation factors			
		d		D	C	B	r min.	dyn. C <sub>r</sub> kN	stat. C <sub>0r</sub> kN	e	Y <sub>1</sub>	Y <sub>2</sub>	Y <sub>0</sub>
		inch	mm										
<b>230S.1200</b>	96,5	<b>12</b>	<b>304,8</b>	480	121	186	4	1 870	3 200	0,23	2,9	4,31	2,83
<b>231S.1200</b>	182	<b>12</b>	<b>304,8</b>	540	176	225	5	2 750	4 700	0,29	2,3	3,42	2,25
<b>231S.1207</b>	280	<b>12<sup>7/16</sup></b>	<b>315,913</b>	580	190	258	5	3 100	5 200	0,3	2,26	3,37	2,21
<b>231S.1208</b>	226	<b>12<sup>1/2</sup></b>	<b>317,5</b>	580	190	258	5	3 100	5 200	0,3	2,26	3,37	2,21
<b>230S.1300</b>	165	<b>13</b>	<b>330,2</b>	540	134	205	5	2 380	4 150	0,22	3,01	4,48	2,94
<b>231S.1300</b>	288	<b>13</b>	<b>330,2</b>	600	192	270	5	3 900	6 800	0,3	2,25	3,34	2,2
<b>231S.1308</b>	314	<b>13<sup>1/2</sup></b>	<b>342,9</b>	600	192	270	5	3 900	6 800	0,3	2,25	3,34	2,2
<b>230S.1400</b>	158	<b>14</b>	<b>355,6</b>	560	135	218	5	2 550	4 600	0,22	3,1	4,62	3,03
<b>231S.1400</b>	273	<b>14</b>	<b>355,6</b>	620	194	270	5	3 900	6 900	0,3	2,28	3,39	2,23
<b>230S.1500</b>	192	<b>15</b>	<b>381</b>	600	148	225	5	2 750	5 100	0,21	3,2	4,77	3,13
<b>230S.1600</b>	225	<b>16</b>	<b>406,4</b>	650	157	225	5	3 150	5 800	0,21	3,2	4,77	3,13

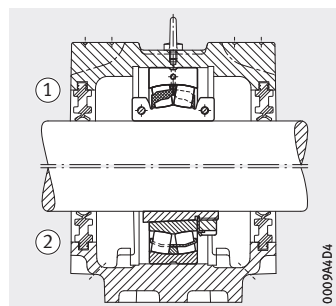
① Split spherical roller bearing. ② Unsplit spherical roller bearing.



Non-locating bearing  
SAF



Locating bearing  
SAF



Non-locating bearing  
SNV

Fatigue limit load $C_{ur}$ N	Permissible axial load $F_a$ max. N	Limiting speed $n_G$ $\text{min}^{-1}$	Screw tightening torque		Replacement of unsplit spherical roller bearing with adapter sleeve			Suitable FAG plummer block housings
			$M_i$ Nm	$M_a$ Nm	Bearing	Adapter sleeve		
260 000	32 000	530	120	69	23064K	H3064-HGX1200	SNP30641200	SDAF064K/12
310 000	60 500	435	295	120	23164K	H3168-HGX1200	–	–
330 000	60 500	400	295	190	23168K	H3168-HGX1207	–	–
330 000	60 500	400	295	190	23168K	H3168-HGX1208	–	–
320 000	60 500	450	295	69	23072K	H3072-HGX1300	SNP30721300	SDAF072K/13
420 000	60 500	360	295	35	23172K	H3172-HGX1300	–	–
420 000	60 500	360	295	35	23172K	H3172-HGX1308	–	–
355 000	60 500	435	295	69	23076K	H3076-HGX1400	SNP30761400	SDAF076K/14
425 000	60 500	350	295	69	23176K	H3176-HGX1400	–	–
360 000	60 500	420	295	120	23080K	H3080-HGX1500	SNP30801500	SDAF080K/15
430 000	60 500	370	295	120	23088K	H3088-HGX1600	–	–

**Schaeffler Australia Pty Ltd**

Suite 3, 13B Narabang Way

Belrose, NSW 2085

Australia

Website: [medias.schaeffler.com.au](https://medias.schaeffler.com.au)

E-mail: [sales.au@schaeffler.com](mailto:sales.au@schaeffler.com)

Phone: +61 2 8977 1010

Every care has been taken to ensure the correctness of the information contained in this publication but no liability can be accepted for any errors or omissions. We reserve the right to make technical changes.

© Schaeffler Technologies AG & Co. KG

Issued: 2020, March

This publication or parts thereof may not be reproduced without our permission.

TPI 250 GB-D

